

50' TELEBOOM



Truly versatile unit offering quick and easy operation



Easy access pumper-style hosebed

50' TELEBOOM

The 50' Teleboom is a perfect complement for communities with townhouses, strip malls, warehouses and rural industry. The combination of a pumper-style body with an elevated master stream creates an extremely versatile apparatus. Its mid-ship, 3-section boom is compact, quick to set up and requires very little swing clearance. And with the aerial controls conveniently located next to the pump operator's panel, the 50' Teleboom is easily operated with limited manpower.

With over 24-years of aerial experience and an excellent safety record, E-ONE continues delivering on our founding principles of innovation and safety. The chassis features the industry's most durable roll cage cab design. The aerial provides a 2.5 to 1 structural safety factor exceeding NFPA requirements.

Whether it's your first aerial, or expanding your existing fleet, you owe it to your department to check out all the features the 50' Teleboom has to offer.

- Typhoon® or Cyclone® II chassis with 3/16" aluminum cab
- Extruded-aluminum body
- Mid-mounted, 3-section aluminum boom with 2.5 to 1 structural safety factor**
- 300-lbs. tip-load (250 lbs. + 50 lbs. equipment)
- 1000-GPM waterway
- Single-person aerial and pump operation
- 750-gallon water tank
- 65 cu. ft. of hosebed storage
- 1250- to 2000-GPM pump



50' TELEBOOM

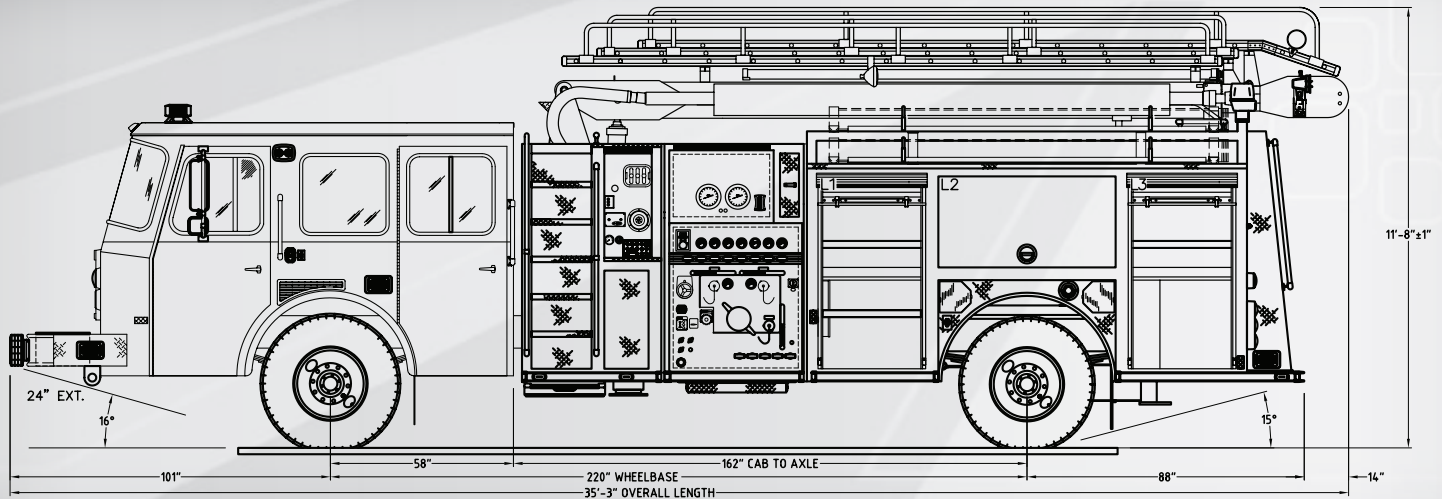

CHASSIS FEATURES

- Typhoon® or Cyclone® II
- 330- to 515-HP engine with auxiliary brake
- Detroit and Cummins
- EVS3000 / EVS4000 transmission

CHASSIS OPTIONS

- 12" vista roof
- Air conditioning
- Front disc brakes
- Aluminum wheels
- Heated mirrors
- Paddle style cab door latches
- 20" bumper extension with or without center-mounted storage tray
- Medical cabinets (IPO rearward facing fixed SCBA seats)

BODY FEATURES

- Full-height driver side compartmentation with rescue style openings
- Half-height officer side compartmentation with adjustable track ladder storage
- Full-height rear body compartmentation with roll-up door
- Easy boom access with staircase
- 750-gallon polypropylene water tank with lifetime warranty
- 65 cu. ft. of hosebed storage

BODY OPTIONS

- Full-height officer side compartmentation with rescue style openings and overhead zico ladder rack
- Roll-up side compartment doors
- 30-gallon integral foam cell
- Wheel well SCBA bottle storage
- 8kW hydraulic generator

PUMP MODULE FEATURES

- Hale® or Waterous® pumps
- Side-mount control panel with slide-out pump operator's platform
- Optional foam system

ELECTRICAL FEATURES

- Federal upper-level and lower-level NFPA warning lighting
- Federal siren with speaker
- Multiplex electrical system



Aerial module provides large officer's-side compartments



Single person pump and boom operation simplifies operation



For a dealer nearest you contact us at www.e-one.com or call 352.237.1122.

A Subsidiary of Federal Signal Corporation.
©2007 E-ONE, Inc. 701-01-301

WHEN LIVES ARE IN THE BALANCE AND SECONDS COUNT